

„ECO-FRESH 01“

Save Energy

HEAT RECOVERY VENTILATION UNIT

Many modern homes are heated with solid fuel systems. In most cases the heating system is designed unprofessional and without provided input of fresh entering the room. Despite popular belief – the regular opening of doors and windows is not an effective solution.

When the oxygen entering the premise is not sufficient, the result is incomplete combustion which forms carbon monoxide - a highly poisonous gas with no odor or color.

CO threatens our lives and health, and is the cause of accidents in heating with solid fuels.

To ensure healthy microclimate the solid fuel stove must get fresh air at least 4 m³/h for each kW of thermal capacity, while to fireplace with open fire, depending on the size, this value is many times greater.

Considering the need of positive pressure in the room with your fireplace, the use of airflow system that delivers clean air is both essential for good combustion of your heater and your health.

MMotors provides a solution for this problem through a series COMPACT VENTILATION SYSTEMS "ECO-FRESH 01"

Air-flow system Eco-Fresh purifies the air from odors, dust, bacteria and car exhaust gases.

The device has embedded hydrostat that controls the humidity in the room, keeping it in the range below 75% which prevents humidification and mold growth.

Emitted during unit's operation negatively charged ions that destroy the disease-causing microorganisms, prevent the spread of infections. Ionized air improves the work capacity, removes fatigue and helps the recovery after long and heavy illness. It also has a beneficial effect in cases of bronchial asthma, respiratory diseases, migraine, neurosis and cardiovascular problems.

CREATE CLEAN AND HEALTHY ENVIRONMENT

- ensures fresh air and healthy microclimate in the premises;
- stale air exhaust;
- creates an overpressure supporting the full combustion and flue gases removal;
- controls humidity and prevent mold growth;
- inlet of purified and ionized air;
- the use of "heat recovery" leads to significant energy saving and reductions of heat loss;
- easy for installation and maintenance. Release

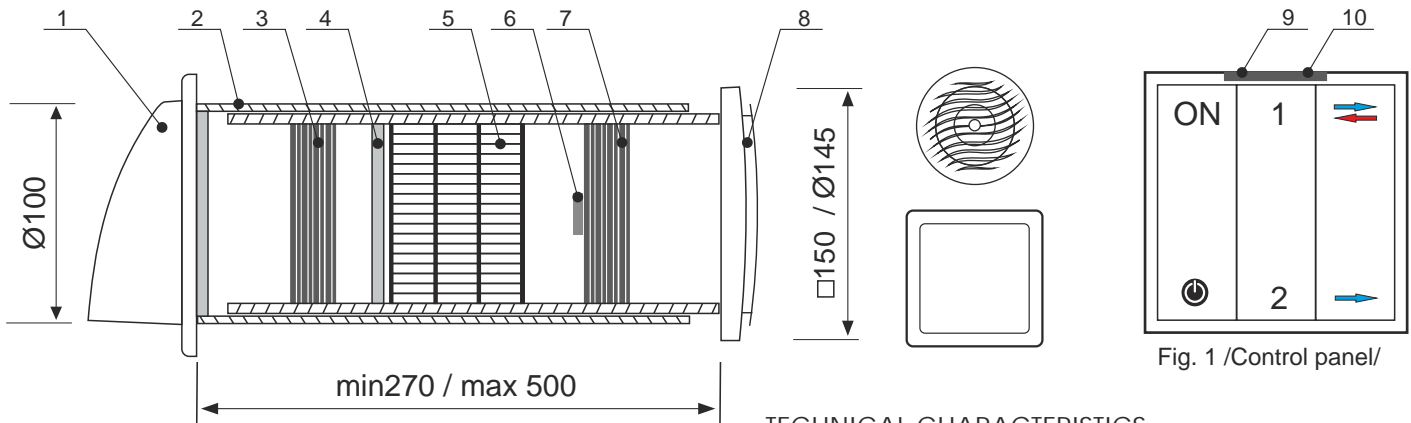

Fig. 1 /Control panel/

The airflow system "Eco-Fresh 01" is composed of:

1. Outer protective grille – protects the system from humidity even during heavy rains.
2. Extensible air funnel – allows regulation of the system length, depending on wall thickness.
3. Exhaust fan – two-speed, allows regulation of fan duty from 30m³/h in night silent mode, up to 100m³/h in day mode.
4. Filter:
 - **Filter with charcoal** – guarantees the clean airflow even in strong polluted urban areas and industrial regions. Cleans the air from smells, dust, bacteria, soot, car exhaust gases and other.
 - **Fine filter** – used in very dusty regions.
5. Heat exchanger – contributes to a significant reduction of heat loss during ventilation.
6. Ionizer – filling up the air with negative ions.
7. Blast fan – two-speed, allows regulation of fan duty from 30m³/h in night silent mode, up to 100m³/h in day mode.
8. Decorative grille – does not take any space in the room, can be executed in different colors.
9. Humidity sensor – turns on the system when the humidity exceeds 70%.
10. CO (carbon monoxide) sensor: turns on the blast fan in mode AIR FLOW → 100 m³/h at detected CO leakage into the premise.

TECHNICAL CHARACTERISTICS

Model	Rated Voltage Hz/V	Maximum Flow m ³ /h	Power Consumption	Maximum rotational speed min ⁻¹	Protection Degree IP
			fan		
O1	50/230	30 / 100	5,5 / 18	1350 / 2650	X4

Dimensions /mm/

Minimal wall thickness 27 cm.
Maximal wall thickness 50 cm.

* The development of a ventilation system, adjusted to other than the above wall thickness is possible by a clients request.

CONTROL PANEL (Fig. 1)

ON - switches on the system.

Standby ⏻

- stops the fan and ionizer, but keeping them in standby mode. The system monitors the air for CO presence and if it is detected the blast fan is automatically turned on at maximum speed. A positive pressure is formed which increases the draught. The atmospheric oxygen contributes to full combustion, in mean time the positive pressure insures the toxic gases disposal through the chimney.
The system monitors the humidity in the room and when it exceeds 75% automatically turns on the fan and ionizer. They stop 10 minutes after the room humidity falls below 75%

FAN SPEED – operate the fan speed. A selection between 5 speeds –

1. first speed – 30m³/h in night silent mode,
2. second speed – max. 100m³/h in day mode.

AIR FLOW →

- Mode "Air Influx" – the system is constantly blasting clean air from outside to inside.

AIR FLOW ↔ (usage at non working fire place)

- Mode of reversible ventilation with thermal energy recovery
The system blasts clean air from outside to inside and disposes polluted air out of the room. A heat recovery is observed – process of recovering heat from outgoing warm but polluted air.
The warm air which is going out through exchanger is rendering its heat to the incoming clean air. This contributes to a significant reduction of heat loss during winter days. In summer the opposite process is observed – the cool air from air-conditioning which is going out through exchanger is chilling the incoming clean but warm air. In the exchanger is achieved efficiency of heat regeneration that exceeds 90%.

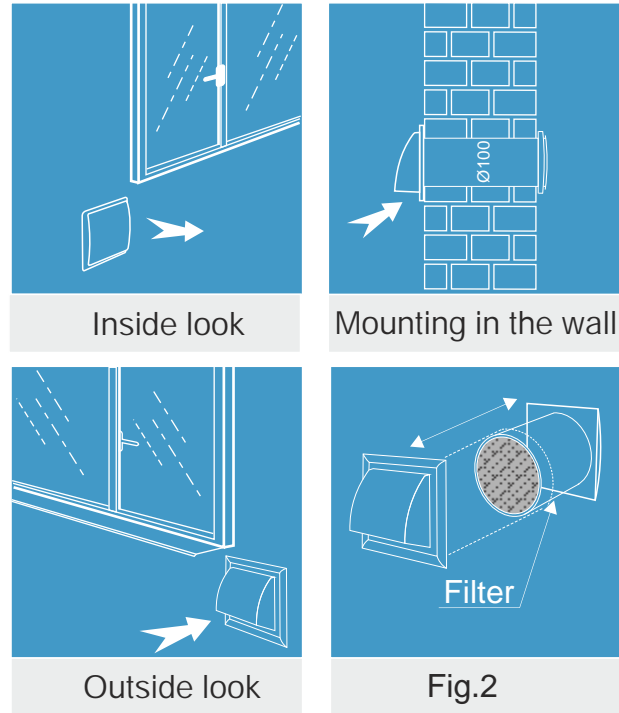

CAUTION: only AIR FLOW → must be used with working fireplace.

From producer:

With unlit fireplace "Eco-Fresh 01" is recommended to work in AIR FLOW ↔ mode at first speed 24 hours a day.

"Eco-Fresh" Standard

- ✓ Reversible air flow
- ✓ Ceramic heat exchanger
- ✓ Hydrostat
- ✓ Active charcoal filter
- ✓ Fine filter